

Optima Geocoil - OGC

300 l.

EN



SAFETY INFORMATION
O&M INFORMATION
INSTALLATION MANUAL
TDS - TECHNICAL DATA SHEET

Manufactured by OSO Hotwater AS
Industriveien 1 - 3300 Hokksund - Norway
Tel: +47 32 25 00 00 / E-mail: oso@oso.no
www.osohotwater.com

11002237-145956-05 - 02-2023

OSO
HOT WATER

CONTENTS

| | |
|---|----|
| 1. Safety instructions | 3 |
| 1.1 General information..... | 3 |
| 1.2 Safety instructions for users..... | 4 |
| 1.3 Safety instructions for installers..... | 4 |
| 2. Product description | 5 |
| 2.1 Product identification..... | 5 |
| 2.2 Intended use..... | 5 |
| 2.3 CE marking..... | 5 |
| 2.4 Technical data..... | 5 |
| 2.5 ErP data (TDS)..... | 5 |
| 3. Installation instructions | 6 |
| 3.1 Products covered by these instructions | 6 |
| 3.2 Included in delivery..... | 6 |
| 3.3 Product dimensions..... | 6 |
| 3.4 Connection heights..... | 6 |
| 3.5 Requirements for installation location .. | 7 |
| 3.6 Pipe installation..... | 8 |
| 3.7 Electrical installation..... | 10 |
| 4. Initial commissioning | 12 |
| 4.1 Filling with water..... | 12 |
| 4.2 Turning on the power..... | 12 |
| 4.3 Control points..... | 12 |
| 4.4 Emptying of water..... | 12 |
| 4.5 Handover to end-user..... | 13 |
| 5. User guide | 14 |
| 5.1 Settings..... | 14 |
| 5.2 Annual inspection..... | 15 |
| 5.3 Maintenance..... | 15 |
| 6. Troubleshooting | 16 |
| 6.1 Faults and fixes..... | 16 |
| 7. Warranty conditions | 18 |
| 7.1 Warranty and registration..... | 18 |
| 7.2 Customer service..... | 18 |
| 8. Removing the product | 18 |
| 8.1 Removal..... | 18 |
| 8.2 Returns scheme..... | 18 |
| 9. System rating | 19 |
| 9.1 Energy labelling of heating systems..... | 19 |



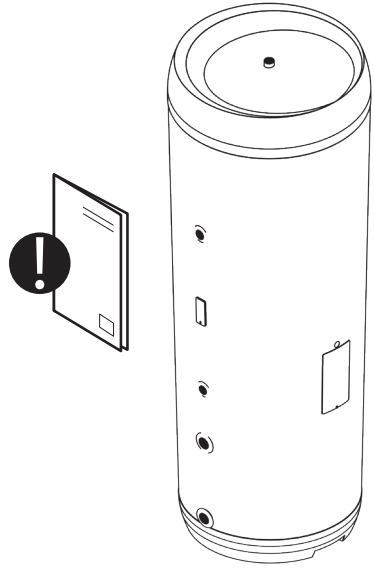

1. SAFETY INSTRUCTIONS

1.1 General information







- Read the following safety instructions carefully before installing, maintaining or adjusting the water heater.
- Personal injury or material damage may result if the product is not installed or used in the intended manner.
- Keep this manual and other relevant documents where they are accessible for future reference.
- The manufacturer assumes compliance (by the end-user) with the safety, operating and maintenance instructions supplied and (by the installer) with the fitting manual and relevant standards and regulations in effect at the date of installation.





Symbols used in this manual:







| | |
|--|--|
|  WARNING | Could cause serious injury or death |
|  CAUTION | Could cause minor or moderate injury or damage to property |
|  DO NOT | |
|  DO | |





1.2 Safety instructions for users

|  WARNING | |
|---|---|
|  | The overflow from the safety valve shall NOT be sealed or plugged. |
|  | The product shall NOT be covered over the electric junction box covers on the front. |
|  | The product shall NOT be modified or changed from its original state. |
|  | Children shall NOT play with the product or go near it without supervision. |
|  | The product shall be filled with water before the power is switched on. |
|  | Maintenance/settings shall only be carried out by persons over 18 years of age, with sufficient understanding |

|  CAUTION | |
|---|--|
|  | The product must not be exposed to frost, over-pressure, over-voltage or chlorine treatment. See warranty provisions. |
|  | Maintenance/settings shall not be carried out by persons of diminished physical or mental capacity, unless they have been instructed in the correct use by someone responsible for their safety. |

1.3 Safety instructions for installers

|  WARNING | |
|---|---|
|  | The overflow from the safety valve shall NOT be sealed or plugged. |
|  | The discharge pipe from any safety device shall be at least one pipe size larger than the nominal outlet size of the safety device (< 9m length). The discharge pipe shall have continuous fall to drain, be uninterruptable and frost-free at all times. |
|  | The electrical supply to the heater shall be done in accordance with current local regulations and best practice by a qualified electrician. The product is intended for permanent supply. |
|  | The mains power supply cable shall withstand 90°C. A strain reliever shall be fitted. |
|  | The product shall be filled with water before the power is switched on. |
|  | The relevant regulations and standards, and this installation manual, shall be followed. |

|  CAUTION | |
|---|--|
|  | The product shall be placed in a room with a floor drain. The manufacturer assumes no responsibility whatsoever if this provision is not followed. |
|  | The product shall be properly aligned vertically and horizontally, on a floor or suitable for the total weight of the product when in operation. See type plate. |
|  | The product shall have a clearance for servicing of 40 cm in front of the electric cover / 10 cm over the highest point. |

2. PRODUCT DESCRIPTION

2.1 Product identification

Identification details for your product can be found on the type plate fixed to the product. The type plate contains details of the product in accordance with EN 12897:2016 and EN 60335-2-21, as well as other useful data. See Declaration of Conformity at www.osohotwater.com for more information.

OSO products are designed and manufactured in accordance with:

- Pressure vessel standard EN 12897:2016
- Safety standard EN 60335-2-21
- Welding standard EN ISO 3834-2

OSO Hotwater AS is certified for

- Quality ISO 9001
- Environment ISO 14001
- Work environment ISO 45001

2.2 Intended use

The Optima OGC is designed to deliver domestic hot water and hydronic heat from an electrical and/or external energy source. OGC 300 can be used with a heat pump with tap water prioritisation. Lower cylinder is used for the heating system. Upper cylinder is used for domestic hot water. OGC is fitted with electric backup.

2.3 CE marking



The CE mark shows that the product complies with the relevant Directives. See Declaration of Conformity at www.osohotwater.com for more information.

The product complies with Directives for:

- Low voltage LVD 2014/35/EU
- Electromagnetic compatibility EMC 2014/30/EU
- Pressurised equipment PED 2014/68/EU

Any safety valve(s) used should be CE-marked and comply with the PED 2014/68/EU.

2.4 Technical data

| Product no. | Product code: | IP class | Capacity, persons | Weight kg. | Dia. x Height mm. | Freight vol. m ³ | Volume L | Suitable for |
|-------------|---|----------|-------------------|------------|-------------------|-----------------------------|----------|--------------|
| 800 0242 | OGC 300 - 3kW - 1x230V+HX 1,8m ² | IP21 | - | 68 | ø595x1760 | 0,64 | 275 | HP |

2.5 ErP data - Technical Data Sheet

| Brand | Model-no. | Model name | ErP Rating | Heat loss W | Real volume L |
|---|-----------|------------|--|-------------|---------------|
| OSO Hotwater AS | 11009417 | OGC 300 | B | 54 | 223/62 |
| Regulation: 2017/1369/EU - Regulation: EU 812/2013 | | | Directive: 2009/125/EC - Regulation: EU 814/2013 | | |
| Efficiency-tested according to standard: EN 50440: 2015 | | | | | |

3. INSTALLATION INSTRUCTIONS

3.1 Products covered by these instructions

800 0242 OGC 300

3.2 Included in delivery

| Ref no. | Pcs. | Description |
|---------|------|--|
| 1 | 1 | Water heater |
| 2 | 1 | Installation manual (this document) |
| 3 | 2 | Sensor slot (factory-fitted) |
| 4 | 2 | Thermostat |
| 5 | 1 | Heating element |
| 6 | 1 | PG strain reliever |
| 7 | 1 | Safety valve for upper cyl. (factory-fitted) |
| 8 | 3 | Adjustable feet (factory-fitted) |

3.3 Product dimensions

All dimensions in mm.

| Product | A | B | C | ∅ |
|---------|------|------|-----|-----|
| OGC 300 | 0-40 | 1753 | 766 | 595 |

Tolerance +/- 5 mm (not dimension A).

3.4 Connection heights

All dimensions in mm.

| Product | D | E | F | G | H | I |
|---------|------|-----|-----|-----|-----|------|
| OGC 300 | 1286 | 154 | 469 | 686 | 666 | 1753 |

Tolerance +/- 5 mm.

3.4.1 Connections - dimensions and function

| Conn- ection | Dimension | Function |
|-----------------|-----------|-----------------------------|
| C | G 3/4" F | Safety valve |
| D | G 3/4" F | Coil connection, upper |
| E | G 1" F | Flow/return, lower cylinder |
| F | G 1" F | Flow/return, lower cylinder |
| G | G 3/4" F | Coil connection, lower |
| H | G 3/4" F | Cold water inlet |
| I | G 3/4" F | Hot water outlet |

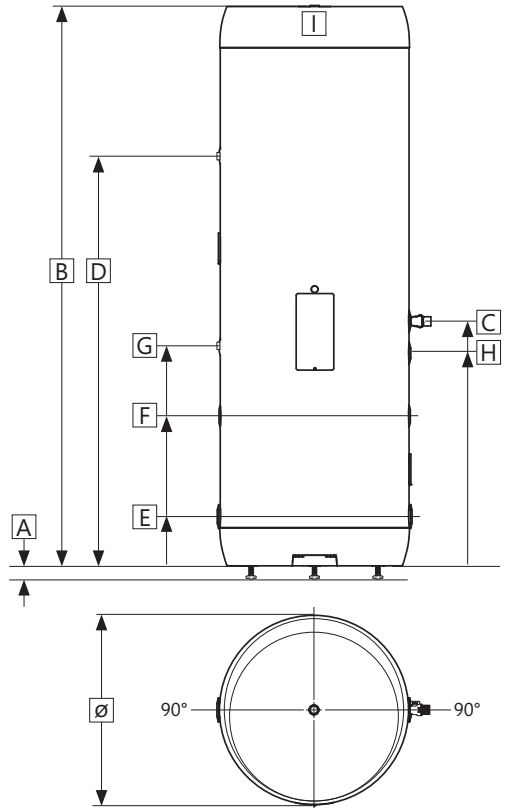
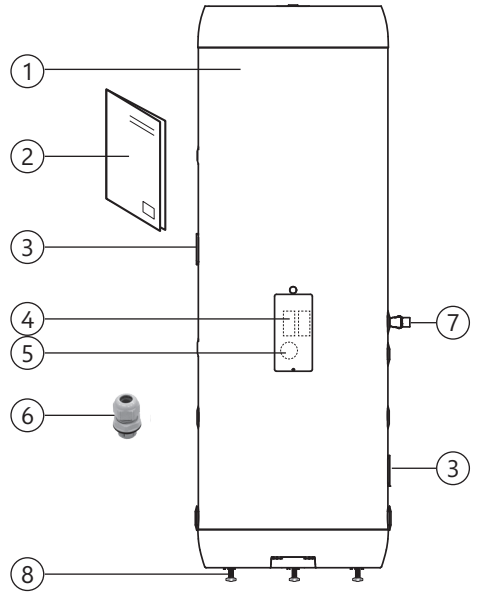

3.4.2 Delivery

The product should be transported carefully as shown, with packaging. Use the handles in the box.

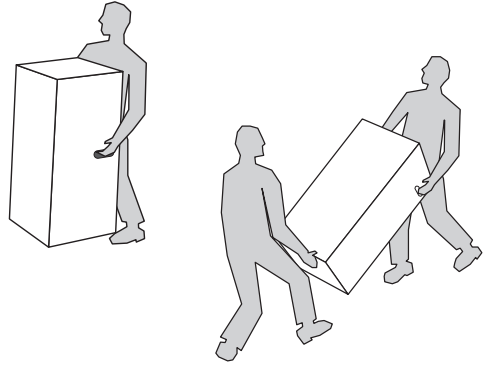

| |
|--|
| ⚠ CAUTION |
| Pipe stubs, valves etc. should not be used to lift the product as this could cause malfunctions. |

3.5 Requirements for installation location and positioning

| ⚠ CAUTION | |
|------------------|--|
| ❗ | The product shall be placed in a room with a drain, and fitted in accordance with local rules and regulations. Alternatively, fit an automatic stop valve with sensor and overflow from safety valve to drain. |
| ❗ | The product shall be placed in a dry and permanently frost-free position. |
| ❗ | The product shall be placed on a floor or wall suitable for the total weight of the product when in operation. See data plate. |
| ❗ | The product shall have a clearance for servicing of 40 cm in front of the electric cover / 10 cm over the highest point. |
| ❗ | The product shall be easily accessible in the home for servicing and maintenance. |

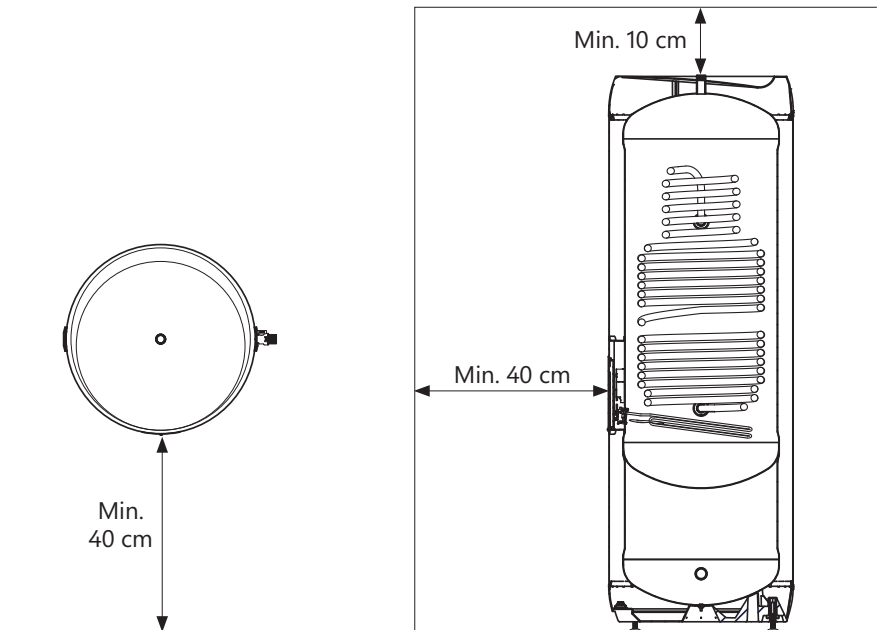

3.6 Pipe installation

The product DHW cylinder (upper) is designed to be permanently connected to the mains water supply. Approved pipes of the correct size should be used for installation. The relevant standards and regulations must be followed.

| Product. | COLD WATER (4) | HOT WATER (1) | Overflow (3) |
|----------|-------------------|------------------|-----------------|
| OGC 300 | G 3/4" F | G 3/4" F | G 3/4" F |

3.6.1 Incoming water pressure

The efficiency of the product depends on the incoming cold water pressure. The water pressure should be min. 2 bar and max. 6 bar throughout the day. Excessive water pressure can be adjusted by installing a pressure reduction valve. In the heating cylinder (lower) the pressure shall not exceed 3 bar.

3.6.2 Fitting cold and hot water pipes (CW-HW) and overflow pipes

- A. Run pipes of suitable size to the hot and cold water connections shown, and affix with suitable sealant. See pt. 3.6.3 for torque settings. Unused connections must be plugged securely.
- B. An overflow pipe (9) in a suitable dimension is run to the safety valve; Connects to the overflow on the safety valve. Must be fitted uninterrupted, undamaged and frost-free with a fall to a suitable drain. See illustration.

3.6.3 Torque settings

| Component | Torque |
|---|---------------|
| Conn. cold & hot water, coil & safety valve | 30 Nm (+/- 3) |
| Flow/return connections - lower cylinder | 60 Nm (+/- 5) |

3.6.4 Installation of flow/return pipe

Pipes of suitable dimensions and quality are led to flow/return connections to coil (5) and lower cylinder (6) as required. Fit with a suitable thread sealant. Make sure that all air is evacuated from the coil when filling.

A safety valve suitable for the system configuration must be placed in a suitable place in the heating circuit from the lower cylinder (not supplied).

Connection dimensions, see section 3.4.1.

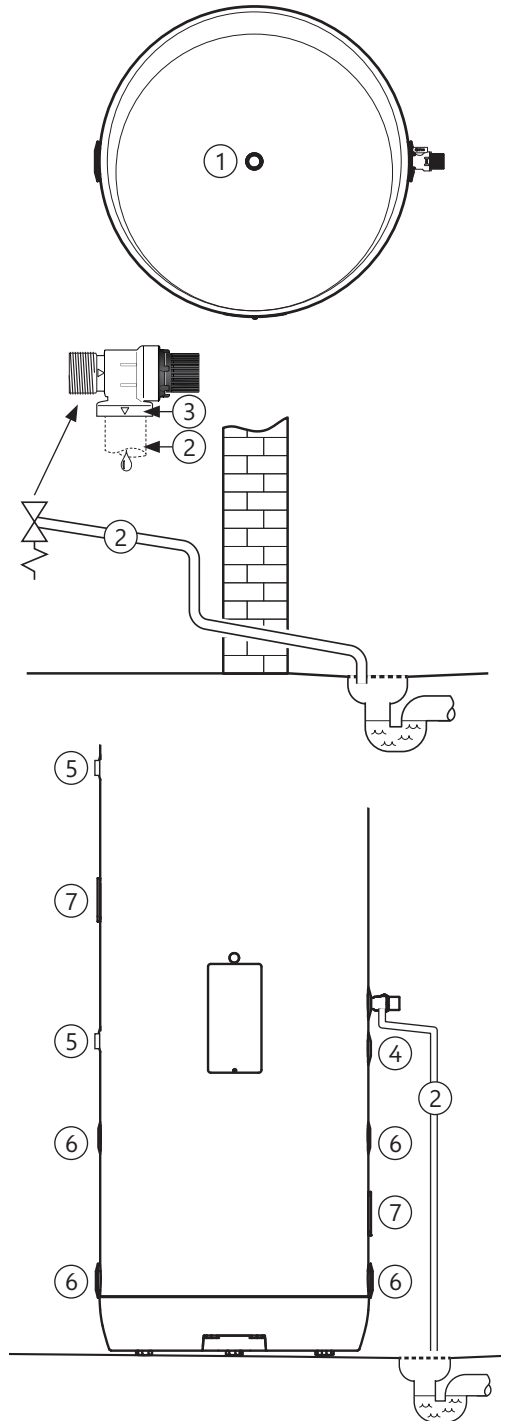

3.6.4 Fitting instructions

⚠ WARNING

| | |
|---|---|
| ❗ | The product shall be filled with water before the power is switched on. Upper cylinder shall be filled first. |
| ❗ | The discharge pipe from any safety device shall be at least one pipe size larger than the nominal outlet size of the safety device (< 9m length). The discharge pipe shall have continuous fall to drain, be uninterrupted and frost-free at all times. |

⚠ CAUTION

| | |
|---|--|
| ❗ | The product shall be placed in a room with a drain, and fitted in accordance with local rules and regulations. Alternatively, fit an automatic stop valve with sensor and overflow from safety valve to drain. |
| ❗ | The product shall be properly aligned vertically and horizontally, on a floor or wall suitable for the total weight of the product when in operation. See type plate. |
| ❗ | The product shall have a clearance for servicing of 40 cm in front of the electric cover / 10 cm over the highest point. |

3.6.5 Fitting recommendation

RECOMMENDATION

| | |
|---|--|
| - | Allow clearance to the floor. Unscrew the feet a minimum of 15 mm from the bottom of the product. |
| - | The power supply cable can be fitted securely in the channels in the product base. |
| - | If a non-return valve is fitted, a reduction valve and expansion vessel shall be fitted to avoid dripping from the safety valve |
| - | If the maximum water pressure exceeds 6 bar in a 24-hour period, a reduction valve and expansion vessel shall be fitted in connection with the DHW cylinder. |

3.6.6 Connection suggestion - schematic

The sketch below shows a simplified, suggested connection option and is not complete with all necessary technical details, valves etc.

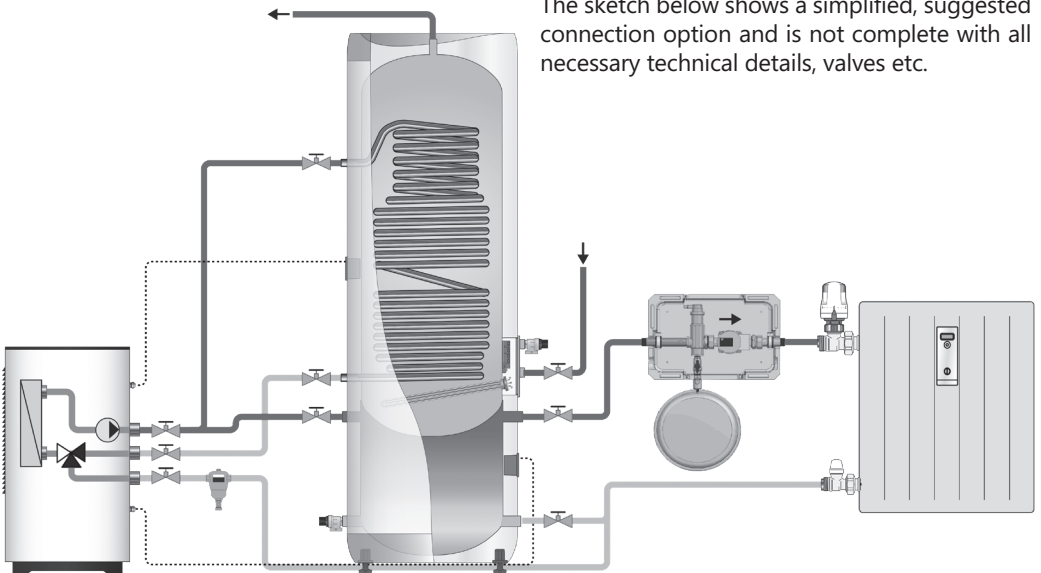

3.7 Electrical installation

Fixed electrical fittings must be used for installation of OGC domestic heating units. Any electric fittings must be installed by an authorised electrician. The relevant standards and regulations must be followed.

3.7.1 Electrical components

| Component | Note |
|-----------------------------|----------------------|
| Safety thermostat | 98°C thermal cut-out |
| Work thermostat, upper cyl. | 60-90°C adjustable |
| Heating element, upper cyl. | 1-ph. 230V 1-barrel |
| Internal wires | Heat-resistant |

⚠ WARNING

Continuous voltage is present at the terminals in the junction box. Before any electrical work is done, the power supply must be disconnected and secured against activation while the work is in progress.

3.7.2 Electrical connections in the junction box

- Live wire (L) is connected to point '1' on the safety thermostat.
- Neutral wire (N) is connected to point '3' on the safety thermostat.
- Yellow wire with green stripe (⊕) – Earth – is connected to the terminal for the heating element (hexagonal brass).
- Internal wires from the element to the thermostat are connected to point '4' on the safety thermostat and point '2' on the work thermostat. See illustration.

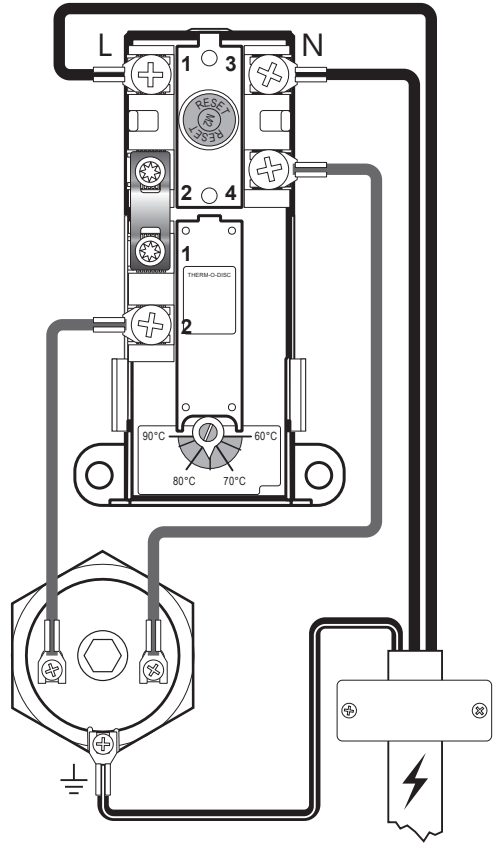

Wiring diagram, schematic

3.7.3 Strain relief

Strain relief (1) is supplied with the product and shall be fitted in the prefabricated cable inlet (2).

All electrical work must be carried out by an authorised electrician.

3.7.4 Torque settings

| Component | Torque |
|---------------------------|----------------|
| G 1 1/4" heating element | 60 Nm (+/- 5) |
| Thermostat screws | 2 Nm (+/- 0.1) |
| Screw on the element head | 2 Nm (+/- 0.1) |

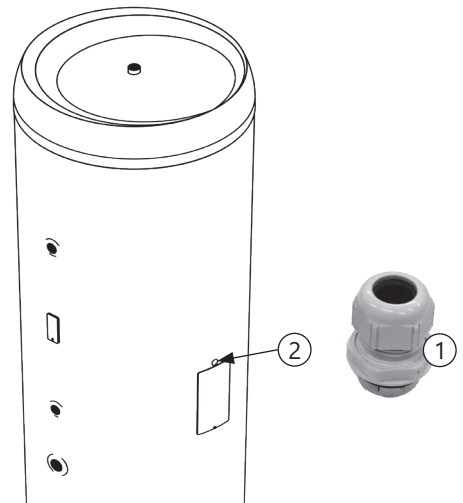

3.7.5 Fitting instructions

⚠ WARNING

| | |
|---|---|
| ❗ | The product shall be filled with water before the power is switched on. Upper cylinder should be filled first. |
| ❗ | Fixed electrical fittings shall be used for installation. Any electric fittings must be installed by an authorised electrician. Components for disconnection must be included in the fixed electrical installation in accordance with applicable standards and regulations. |
| ❗ | Mains cable shall withstand 90°C continuously. A strain reliever must be fitted. |

⚠ CAUTION

| | |
|---|--|
| ❗ | The product shall have a clearance for servicing of 40 cm in front of the electric cover / 10 cm over the highest point. |
| ❗ | In case of damage to the power supply cable, this shall be replaced with custom cable from an authorised electrician. |

3.7.6 Fitting recommendation

RECOMMENDATION

| | |
|---|---|
| - | Mains cable is fed into the junction box through a prefabricated hole in the casing (2). The hole is sized for fitting the supplied strain relief (1). The strain relief shall be fitted. |
| ❗ | For the product power supply a $\geq 15A$ fuse/ $\geq 2.5\#$ wire shall be used. Ensure that all wires, cables and power supply equipment to the product are not in danger of being exposed to mechanical, thermal or chemical influence. |

The power supply cable for the product can be hidden and protected in the channels in the product base, see illustration.

Fixed electrical fittings must be used for installation. All electrical installation shall be carried out by an authorised electrician.

3.7.7 Temperature sensor installation

The product is equipped with a temperature sensor bracket which allows installation of a 6 or 8 mm. temperature sensor. To install the temperature sensor follow the instructions below.

1. Remove temperature sensor bracket (A) from tank body by gripping it and pulling straight out.
2. Insert temperature sensor (B) firmly into the appropriate grooves in the sensor bracket and place the temperature sensor cable in the cable slot (D).
An 8 mm. sensor (shown) fits in the upper grooves (C) while a 6 mm. sensor fits in the lower groove (E).
3. Refit the sensor bracket into the tank body, ensuring the bracket is inserted fully to establish proper contact between the sensor and the stainless steel inner tank surface. Make sure the sensor cable is positioned properly in the cable slot (D) to avoid potential damage to the cable.

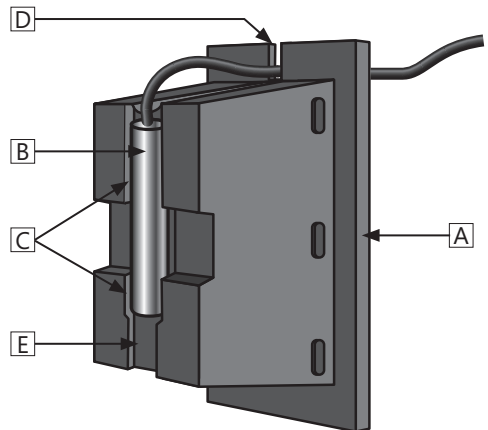
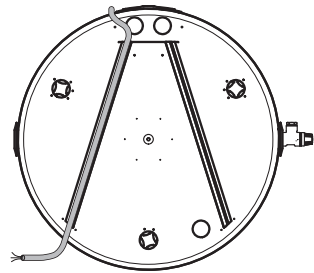

4. INITIAL COMMISSIONING

4.1 Filling with water (upper cylinder first!)

- 1) Upper cylinder: Check that all pipes are connected correctly. Then proceed as follows:
 - A) Open a hot tap – leave it open
 - B) Open the cold water supply to the product. Check that the water from the open hot water tap is flowing freely, without any air locks.
 - C) Close hot tap.
- 2) Lower cylinder: Filled according to the instructions for the external heat source/ heating system. Vent the circuit when filling to avoid air pockets.
- 3) Coil (3) is filled according to the external heat source instructions. Vent the circuit when filling to avoid air pockets.

4.2 Turning on the power

When the cylinder has been filled with water, the power can be switched on.

- A) Switch on breaker/fuse.
- B) When external heat source (HP) is fitted, electric element should only be used for emergency heating.

4.3 Control points

- A) Check that all pipe connections to/from the product are tight and is not leaking.
- B) Check that the power supply to the product is not at risk of exposure to mechanical, thermal or chemical damage.
- C) Check that any overflow pipe from the safety valve is uninterrupted, undamaged and frost-free with a fall to the drain.
- D) Check that the product is standing firmly vertically and horizontally.

4.4 Emptying of water

⚠ WARNING

The water temperature in the product is 75°C and could cause scalding. Before emptying, a hot tap should be opened to the max. pressure/temperature for min. 3 minutes.

Upper cylinder:

- A) Disconnect the power supply.
- B) Shut off incoming cold water supply.
- C) Open a hot water tap to maximum and

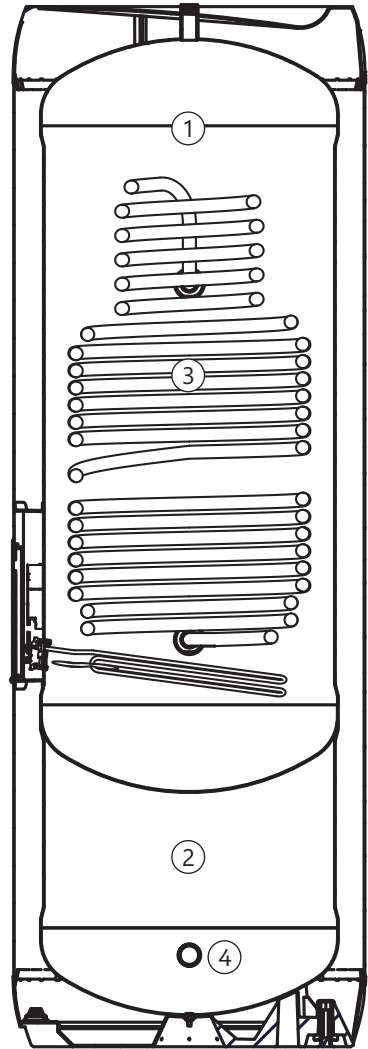

leave open (prevents vacuum).

- D) Turn the knob on the safety valve (5) approx. 90 degrees to the open position. Upper cylinder empties.

After emptying, close the safety valve by turning the knob (5) further clockwise. Close all open taps.

If faster emptying of the upper cylinder is required the safety valve can be removed by unscrewing it from the connection. When re-fitting the valve must be tightened in accordance to the torque setting shown in table 3.6.3. A suitable thread sealant must be used.

Lower cylinder:

If an external heat source is fitted, follow the emptying instructions for this. In electric-only operation: Disconnect the power supply. Disconnect a lower pipe fitting (4). Open a bleed valve or vent the circuit in some other way.

Emptying the coil:

Follow the closing instructions for a connected external heat source. Loosen the pipe to the lower coil connection.

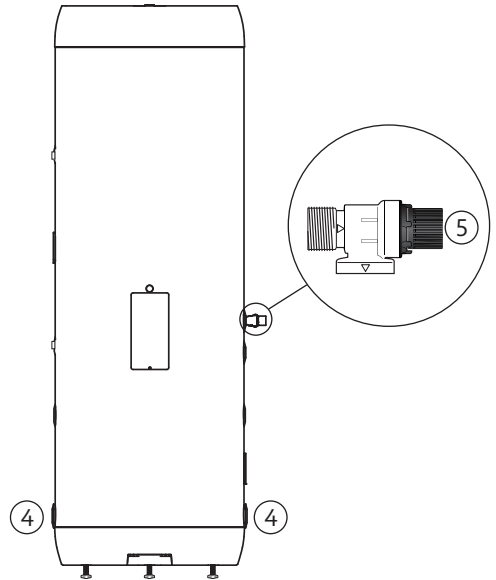

4.5 Handover to end-user

| THE INSTALLER MUST: |
|--|
| Brief the end-user on safety and maintenance instructions. |
| Brief the end-user on settings and emptying the product. |
| Hand this installation manual over to the end-user. |
| Enter contact details on the type plate on the product. |

5. USER GUIDE

5.1 Settings

5.1.1 Thermostat setting

The product's thermostats are adjustable from 60-90°C. The thermostat should not be set lower than 65°C to prevent bacteria growth. To adjust the temperature:

- A) Disconnect the power supply.
- B) Remove the junction box cover with a screwdriver.
- C) Adjust the temperature on the thermostat (7) with a screwdriver.

Refit the junction box cover before connecting the power supply.

5.1.2 Resetting the safety thermostat

The product safety thermostat will cut out when there is a risk of overheating. It can be reset by switching off the power supply, removing the junction box cover and pressing the red 'RESET' button (6).

If the thermostat cuts out repeatedly, contact the installer.

5.1.3 Adjusting the feet

The product is equipped with three factory-fitted feet, adjustable from 0-40 mm. Unscrew the feet a minimum of 15 mm from the bottom of the product. Adjust the feet individually until the product is standing firmly vertically and horizontally.

⚠ WARNING

Continuous voltage is present at the terminals in the junction boxes. Before any electrical work is done, the power supply must be disconnected and secured against activation while the work is in progress.

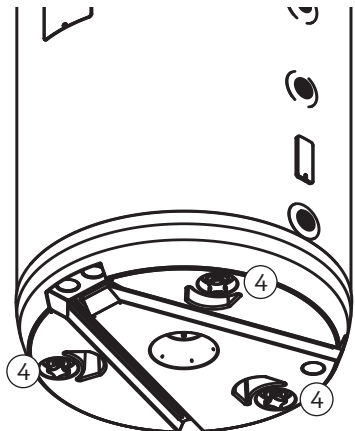
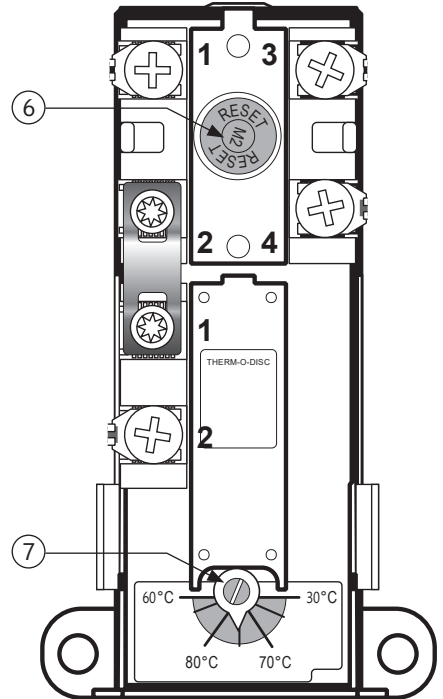

5.2 Annual inspection

- A) Safety valves must be checked annually, see pt. 5.3.
- B) Check that all pipe connections to/from the product are tight and not leaking.
- C) Check that the power supply to the product is not in danger of being exposed to mechanical, thermal or chemical damage. The product shall not be in operation with damaged wiring or connectors. Damaged cables must be replaced with corresponding type and quality by an authorised electrician.
- D) Check that any overflow pipe from the safety valve is uninterrupted and is fitted frost-free and sloping to a suitable drain/gulley.
- D) Check that the product is fitted level and stable.

5.3 Maintenance

MAINTENANCE INSTRUCTIONS

| | |
|---|---|
| ❗ | Maintenance should be carried out by persons over 18 years of age, with sufficient understanding. |
| ❗ | Annual inspection of safety valve: |
| - | Open valve for 1 min. by turning the knob (3) approx. 90 degrees to the open position. |
| - | Visually check that the water is flowing freely to the drain. |
| - | YES = OK. Close the valve by turning the knob (90) a further 90 degrees to the closed position. |
| - | NO = NOT OK. Disconnect power supply / shut off water supply. Contact installer. |

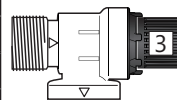

6. TROUBLESHOOTING

6.1 Faults and fixes

If problems arise when the product is in use, check for possible faults and fixes in the table. If the problem is not shown in the troubleshoot-

ing table or you are unsure what is wrong, contact the installer (see type plate on the product) or OSO Hotwater AS - see section 7.1.

| TROUBLESHOOTING, DOMESTIC HOT WATER - UPPER CYLINDER | | |
|---|--|--|
| Problem | Possible cause of fault | Possible solution |
| There is leakage/dripping from the safety valve/there is often water on the floor by the cylinder in the morning | Pressure reduction valve, water meter or blocked non-return valve on the water intake. | Fit AX expansion vessel with absorbs expansion during heating, and fit pressure reduction valve for stable water pressure inside the home. The pressure reduction valve is adjusted in according to the pressure in the expansion vessel. Contact auth. installer. |
| | Water pressure into the home is too high. | |
| | The safety valve is worn or there are particles stuck between the membrane and the valve seat because the water is dirty | Try to flush with water through the safety valve. Open valve for approx. 1 minute. See section 5.2. If the valve still leaks, it must be replaced. Contact auth. installer. |
| No hot water | Leak from heating element. | Verify as follows: a) cut the electric supply, b) unscrew the cover, c) visually check whether there is a leak from the heating element. If so, replace the gasket/heating element. Contact auth. installer. |
| | Power supply interrupted. | Verify that the fuse is on / the plug is plugged in to the wall contact / the earth breaker has not tripped. |
| | Thermostat has cut out. | Press the 'RESET' button on the safety thermostat; see 'User guide'. |
| | Heating element is defective. | Replace heating element. Contact auth. installer. |
| Not enough hot water | Leak in hot water pipe | Verify as follows: a) close the cold water supply, b) wait 2-3 hours, c) touch the product to see whether it is hot. If so, there is a leak in the hot water pipe or elsewhere. Contact auth. installer. |
| | High consumption in the home. | Raise the temperature on the thermostat to 85°C; see 'User guide'. Switch to a larger OSO water heater. Contact auth. installer. |
| Not high enough water temperature | The thermostat is set for low temperatures. | Raise the temperature on the thermostat to 85°C; see 'User guide'. |
| | Change from cold to hot water in taps. | Contact auth. installer. |
| Fuse/earth breaker trips repeatedly | Possible fault in the heater's electrical system. | Verify as follows: a) cut the electric supply, b) unscrew the cover, c) visually check the junction box for any problems. If so, contact auth. installer to check. Fit the cover. |
| Long time before the water reaches the tap | Long stretch of pipe from water heater to tap. | Fit circulation wire or heating cable to HW pipe. Or fit an auxiliary heater by the tap. Contact auth. installer. |
| Knocking in the pipes when the hot tap is closed | Large pressure increase when the tap is closed quickly. | Completely normal. Fit AX expansion vessel if troublesome. Contact auth. installer. |

TROUBLESHOOTING HEATING SYSTEM - LOWER CYLINDER

| Problem | Possible cause of fault | Possible solution |
|--|---|---|
| Heating system provides little or no room heating | The facility lacks power | Check the fuses and power supply wires |
| | Circulation pump is out of operation. | Listen or feel the pump (NB: the pump may be hot) to check whether it is running. If no: Contact auth. installer. |
| | There is air in the system | If an external heat source is fitted, check its instructions for ventilation. In electric-only operation, the system is vented via bleed valves etc. Any radiators are vented individually. Contact auth. Installer when needed. |
| | Return valves are set incorrectly | Check that return valves provide the correct throttling. Contact auth. Installer when needed. |
| The heating system safety valve is dripping/running | The expansion tank is defective | Open the air filling valve on the tank. If water is leaking out, the vessel is broken and must be replaced. |
| | The pressure in the heating system is too high | Check the system pressure. Normal operating pressure is 1-2 bar. Contact auth. Installer when needed. |
| | The valve is defective | Replace the valve. Contact auth. installer. |
| The heating circuit has to be refilled frequently | Leak in the heating system | Check all pipe couplings. Turn off the power supply, remove the lid on the junction box in the lower cylinder and check leakage from heating elements. If there is a leak from the element: Gasket needs to be replaced. Contact auth. installer. The cover should be fitted before switching on the power. |
| Fuse/earth breaker trips repeatedly | Possible fault in the heater's electrical system. | Verify as follows: a) cut the electric supply, b) unscrew the cover, c) visually check the junction box for any problems. If so, contact auth. installer to check. Fit the cover. |

7. WARRANTY CONDITIONS

1. Scope

OSO Hotwater AS (hereinafter called OSO) warrants for 2 years from the date of purchase, that the Product will: i) conform to OSO specification, ii) be free from defects in materials and workmanship, subject to conditions below. All components carry a 2-year warranty.

The warranty is voluntarily extended by OSO to 5 years for the stainless steel inner tank. This extended warranty only applies to Products purchased by a consumer, that has been installed for private use and that has been distributed by OSO or by a distributor where the Products have been originally sold by OSO. The extended warranty does not apply to Products purchased by commercial entities or for Products that have been installed for commercial use. These shall be subject only to the mandatory provisions of the law. The conditions and limitations set out below shall apply.

2. Coverage

If a defect arises and a valid claim is received within the statutory warranty period, at its option and to the extent permitted by law, OSO shall either: i) repair the defect, or; ii) replace the product with a product that is identical or similar in function, or; iii) refund the purchase price.

If a defect arises and a valid claim is received after the statutory warranty period has expired, but within the extended warranty period, OSO will supply a product that is identical or similar in function. OSO will in such cases not cover any other associated costs.

Any exchanged Product or component will become the legal property of OSO. Any valid claim or service does not extend the original warranty. The replacement Product or part does not carry a new warranty.

3. Conditions

The Product is manufactured to suit most public water supplies. However, there are certain water chemistries (outlined below) that can have a detrimental effect on the Product and its life expectancy. If there are uncertainties regarding water quality, the local water supply authority can supply the necessary data.

The warranty applies only if the conditions set out below are met in full:

- The Product has been installed by a professional installer, in accordance with the instructions in the installation manual and all relevant Codes of Practice and Regulations in force at the time of installation.
- The Product has not been modified in any way, tampered with or subjected to misuse and no factory fitted parts have been removed for unauthorized repair or replacement.
- The Product has only been connected to a domestic mains water supply in compliance with the European Drinking Water Directive EN 98/83 EC, or latest version. The water

should not be aggressive, i.e. the water chemistry shall comply with the following:

| | |
|------------------------------------|----------------|
| - Chloride | < 250 mg / L |
| - Electric Conductivity (EC) @25°C | < 750 uS / cm |
| - Saturation Index (LSI) @80°C | > -1,0 / < 0,8 |
| - pH level | > 6,0 / < 9,5 |

- The immersion heater has not been exposed to hardness levels exceeding 10°dH (180 ppm CaCO₃). A water softener is recommended in such cases.
- Any disinfection has been carried out without affecting the Product in any way whatsoever. The Product shall be isolated from any system chlorination.
- The Product has been in regular use from the date of installation. If the Product is not intended to be used for 60 days or more, it must be drained.
- Service and/or repair shall be done according to the installation manual and all relevant codes of practice. Any replacement parts used shall be original OSO spare parts.
- Any third-party costs associated with any claim has been authorized in advance by OSO in writing.
- The purchase invoice and/or installation invoice, a water sample as well as the defective product is made available to OSO upon request.

Failure to follow these instructions and conditions may result in product failure, and water escaping from the Product.

4. Limitations

The warranty does not cover:

- Any fault or costs arising from incorrect installation, incorrect application, lack of regular maintenance in accordance with the installation manual, neglect, accidental or malicious damage, misuse, any alteration, tampering or repair carried out by a non-professional, any fault arising from the tampering with or removal of any factory fitted safety components or measures.
- Any consequential damage or any indirect loss caused by any failure or malfunction of the Product whatsoever.
- Any pipework or any equipment connected to the Product.
- The effects of frost, lightning, voltage variation, lack of water, dry boiling, excess pressure or chlorination procedures.
- The effects of stagnant (de-aerated) water if the Product has been left unused for more than 60 days consecutively.
- Damage caused during transportation. Buyer shall give the carrier notice of such damage.
- Costs arising if the Product is not immediately accessible for servicing.

These warranties do not affect the Buyer's statutory rights.

7.1 Customer service

In case of problems that cannot be resolved with the aid of the troubleshooting guide in this installation manual, contact either:

- A) The installer who supplied the product.
- B) OSO Hotwater AS: Tel.: +47 32 25 00 00
oso@oso.no / www.oso.no

8. REMOVING THE PRODUCT

8.1 Removal

- A) Disconnect the power supply.
- B) Shut off incoming cold water supply.
- C) Empty the product of water – see section 4.4.
- D) Disconnect all pipes.
- E) The product can now be removed.

8.2 Returns scheme

This product is recyclable and should be taken to the environmental recycling centre. If the product is to be replaced with a new one, the installer can take the old cylinder away for recycling.

9. SYSTEM RATING

9.1 Energy labelling of heating systems

The ERP directive requires heating systems to be fully energy labelled. OSO OGC comes with energy labelling for connection to a heat pump.

For the energy labelling requirements to be met, the energy efficiency must be:

- Room heating > 125%
- Tap water > 55%

The attached energy label (see illustration) can be affixed to the product when the system meets the requirements for energy efficiency, as shown above.

Check the heat pump's technical data form (product fiche) for details of its energy efficiency.

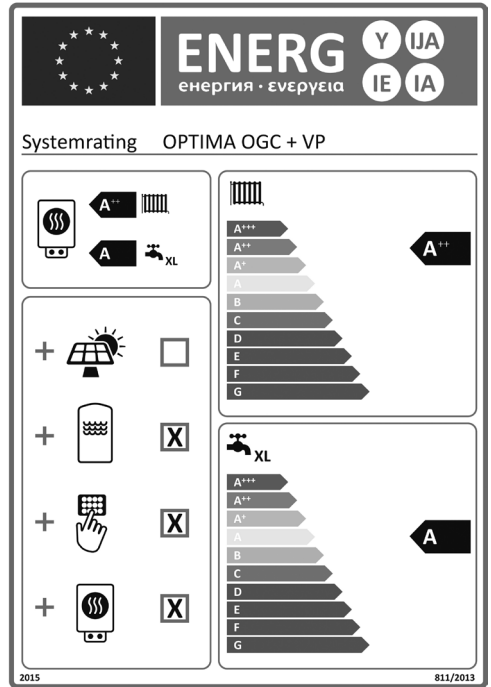

OSO

HOTWATER

OSO Hotwater AS

Industriveien 1
3300 Hokksund - Norway
Tel: + 47 32 25 00 00
oso@oso.no
www.osohotwater.com